



INSTRUCTOR SEATS



ABOUT US

Pilot Seating was established in 1963 doing body work for busses. First seat production started in 1967 with driver seats for Mercedes Benz (Otomarsan - Turkey). Pilot Seating started to manufacture truck and construction equipment seats in 1977, followed by tractor and forklift seats in 1989, passenger seats in 1993 and marine seats in 2010 and railway seats in 2017.

Pilot Seating manufactures in a modern, integrated, purpose built 12000m2 factory including in-house R&D and testing. Pilot also has a separate tooling plant and both plants are located in the industrial zone in Bursa, Turkey. The factory has the ISO9001, IATF16949 and ISO140001 certifications. All the activities including R&D, design and prototype manufacturing, tooling of all seats and parts up to serial production with extensive manufacturing capabilities and in-house validation testing give Pilot flexibility and speed.

This comprehensive and wholly integrated manufacturing and tooling capability allows Pilot Seating to bring new projects to serial production very quickly and / or easily make changes on our standard ranges as well as supplying high quality production consistently and in a timely fashion to our customers. All our seats are extensively and continuously tested for performance and durability and are certified according to applicable ISO and EU standards. Today, Pilot Seating is a well-known brand in seating industry, supplying to OEM and aftermarket customers in various sectors all over the world.



Products;

- Driver Seats
- Construction Seats
- Agricultural Seats
- Material Handling Seats
- Passenger Seats
- Marine Seats
- Railway Seats



Fold up seat cushion	●	N/A	TH12
Fold down backrest	●	N/A	
Vinyl trim (Vacuum type)	●		
Cloth trim (Vacuum type)	▲		
2 Point seat belt	▲		
● Standard ▲ Optional N/A Not available			

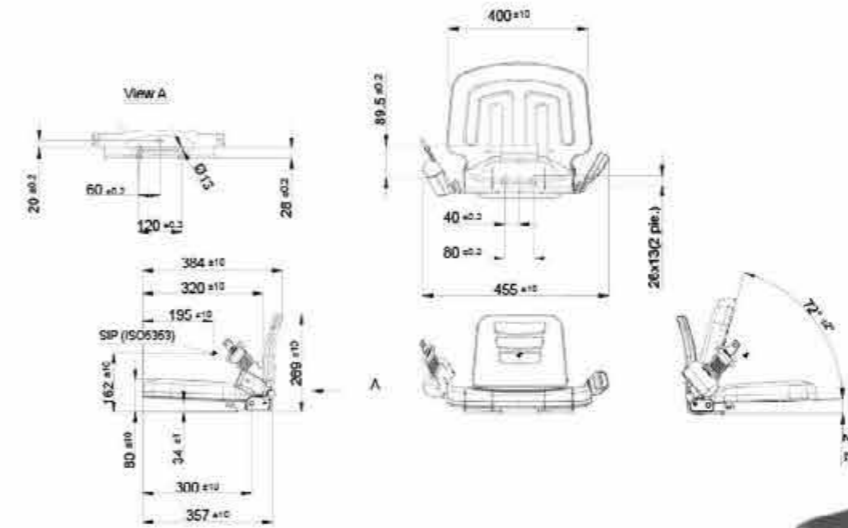

Fold up seat cushion	●	N/A	TH15
Fold down backrest	●	N/A	
Vinyl trim (Vacuum type)	●		
Cloth trim (Vacuum type)	▲		
2 Point seat belt	▲		
● Standard ▲ Optional N/A Not available			

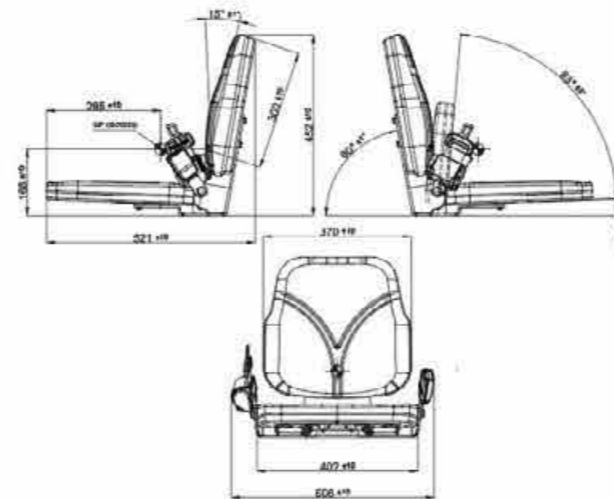

Fold up seat cushion	●
Fold down backrest	●
Vinyl trim (Vacuum type)	●
Cloth trim (Vacuum type)	▲
2 Point seat belt	▲

PFS2001

● Standard ▲ Optional N/A Not available

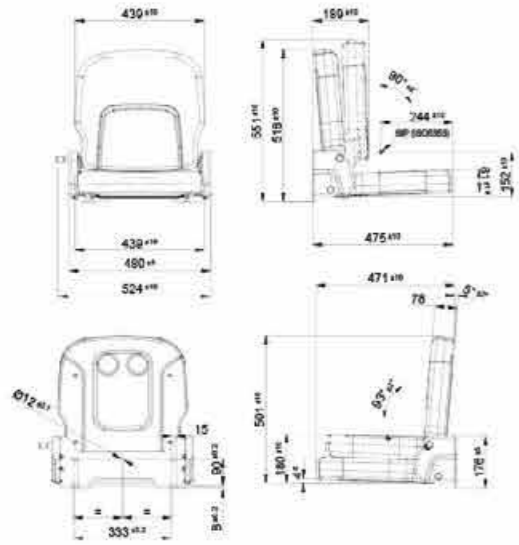

Fold up seat cushion	●
Vinyl trim (Cut & Sew)	●
Cloth trim (Cut & Sew)	▲
2 Point seat belt	N/A

PYH2008

● Standard ▲ Optional N/A Not available

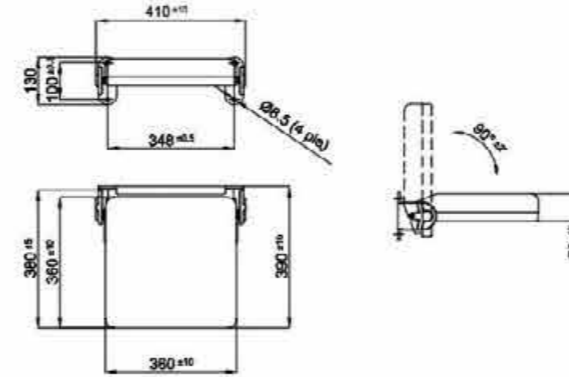

Mechanical suspension	●
Weight adjustment	Manual up to 130 kgs
Fold up seat cushion	●
Fold down backrest	●
Vinyl trim (Vacuum type)	●
Cloth trim (Vacuum type)	▲
2 Point seat belt	▲

PFS2003

● Standard ▲ Optional N/A Not available

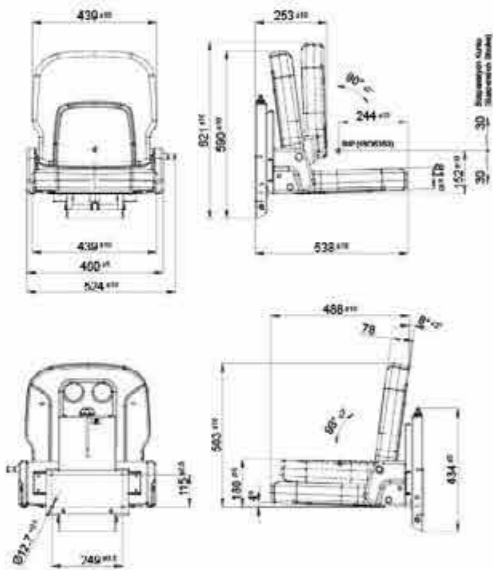

Fold up seat cushion	●
Vinyl trim (Vacuum type)	●
Cloth trim (Vacuum type)	▲
2 Point seat belt	N/A

PYH2113

● Standard ▲ Optional N/A Not available

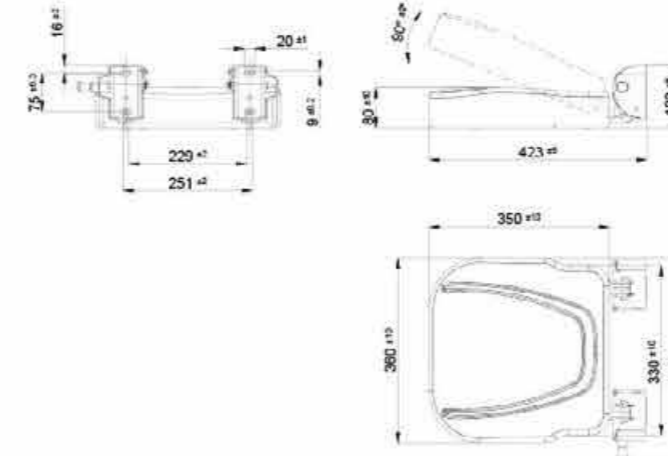

www.pilot.com.tr

Organize Sanayi Bölgesi Kırmızı Cad.
No:7 16140 Nilüfer, BURSA / TÜRKİYE
Phone.: +90 224 411 02 80
pilot@pilot.com.tr